

MAESTRO

WIRELESS INSTALLATION

THIS MANUAL IS DESIGNED TO LEAD YOU STEP BY STEP THROUGH THE PROCEDURES REQUIRED TO TEST, INSTALL AND USE YOUR WIRELESS MAESTRO. BY FOLLOWING THESE PROCEDURES AND SETTING UP THE SYSTEM CORRECTLY IN THE BEGINNING, YOU WILL BE ABLE TO ENJOY ALL THE FEATURES OF YOUR WIRELESS MAESTRO FOR YEARS TO COME. WE STRONGLY SUGGEST THAT YOU PERFORM A TRIAL WIRING OF YOUR WIRELESS MAESTRO PRIOR TO FINAL INSTALLATION.

Locate the **NiCad** Batteries and Battery charger, then charge the batteries according to the charger instructions. You will need them later. The **NiCad** batteries will be kept charged by the solar panel when installed in the transmitter. They should not need replacement for two to three years. When they do need replacement use 1000 milliamp/hour **NiCad** batteries. (Do **NOT** use Alkaline or NiMH batteries.)

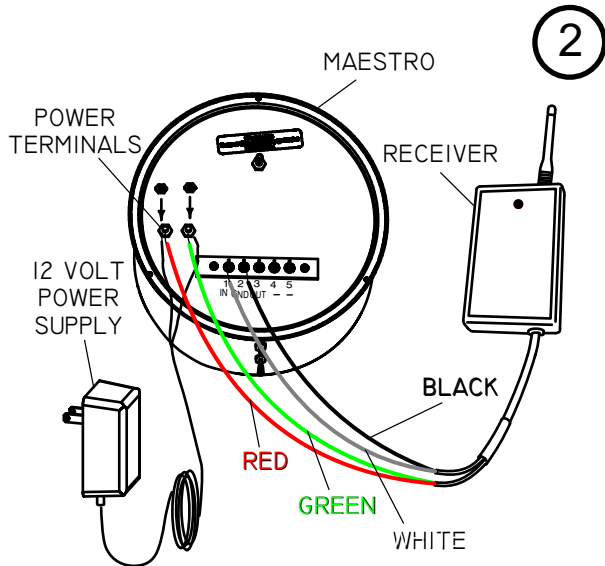
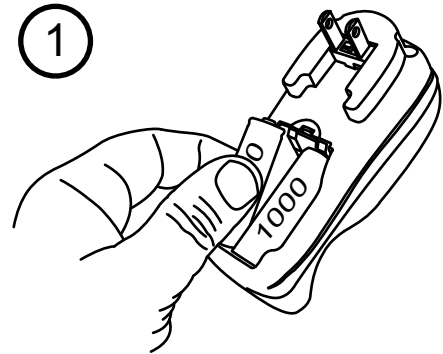

2 You now need to wire your receiver to your display unit. Connect the **RED** and **GREEN** wires from the RECEIVER to the power terminals on the back of the MAESTRO (the polarity does not matter). Connect the wires from the 12 volt power supply to the same power terminals (again the polarity does not matter). Connect the **WHITE** wire from the RECEIVER to TERMINAL #1 and the **BLACK** wire from the RECEIVER to TERMINAL #2 on the rear of the MAESTRO meter.

RECEIVER WIRING	
WHITEto.....TERMINAL #1
BLACKto.....TERMINAL #2
REDto.....Power (no polarity)
GREENto.....Power (no polarity)

Feed the **YELLOW** and **BROWN** wires from the Wireless Wind Transmitter through the small access hole in one of the black rubber boots. Using the solid brass nuts from the Hardware Pack, attach the wires to the two terminals on the Wind Speed Sensor (no polarity). Do **NOT** adjust the nuts that are already on the sensor.

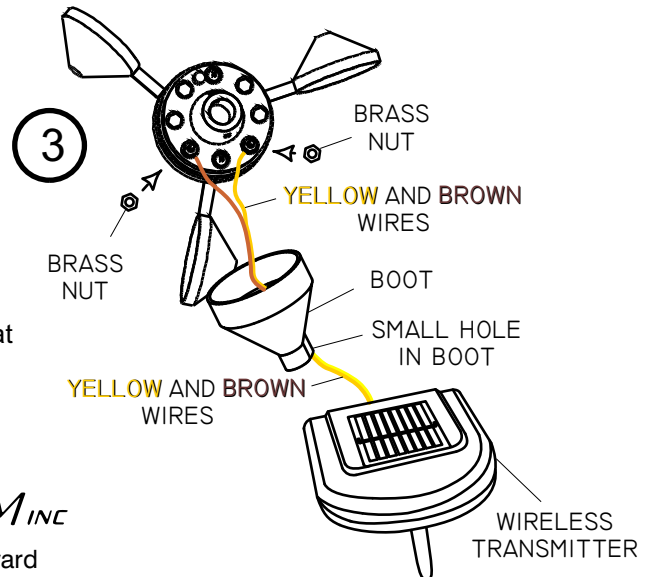

MAESTRO

WIRELESS INSTALLATION

Feed the terminal lug end of the five-conductor cable through the other rubber boot and connect the lugs to the terminals on the bottom of the wind-direction sensor with the brass nuts from the Hardware Pack. Do NOT adjust the nuts that are already on the sensor.

TRANSMITTER WIRING		
WHITE	to	TERMINAL #1
ORANGE	to	TERMINAL #2
BLACK	to	TERMINAL #3
RED	to	TERMINAL #4
GREEN	to	TERMINAL #5

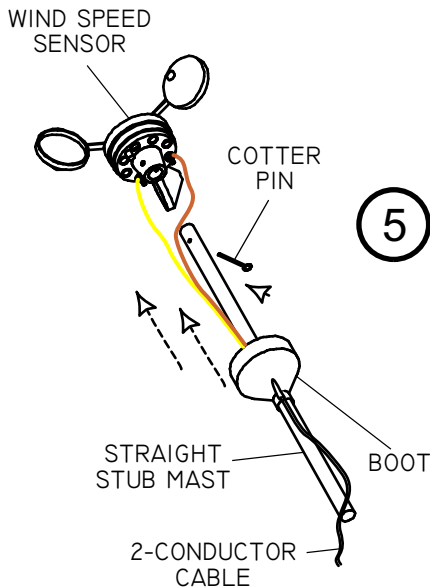
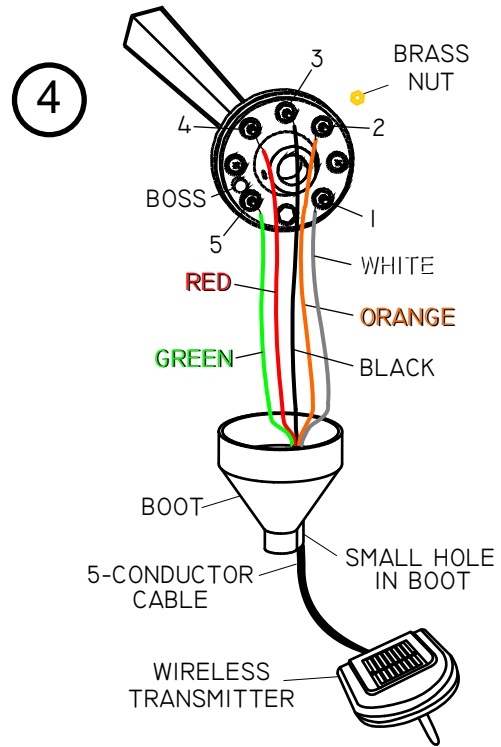

Slide the straight stub mast through the black rubber boot and insert it into the Wind Speed Sensor, securing it with the supplied stainless steel cotter pin. Once the final installation is made and proper function is verified, coat all the wire connections with a silicone sealant designed for electrical connections (not supplied). Slip the boot over the base of the sensor.

Slide the "Z" shaped mast through the black rubber boot and insert it into the Wind Direction Sensor. Align the sensor so that the number 3 terminal is located over the horizontal section of the "Z" shaped mast and secure it with the supplied stainless steel cotter pin. Once the final installation is made and proper function is verified, coat all the wire connections with a silicone sealant designed for electrical connections (not supplied). Slip the boot over the base of the sensor.

Align the sensor so that the number 3 terminal is located over the horizontal section of the "Z" shaped mast

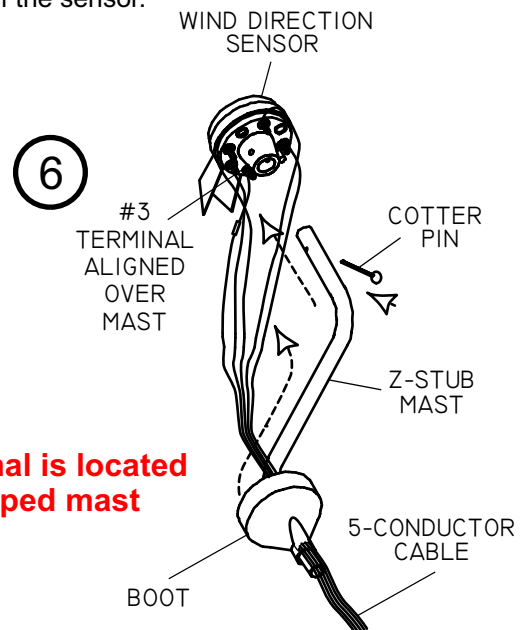

MAXIMUM INC.

30 Barnet Boulevard
New Bedford, MA 02745
(508) 995-2200

MAESTRO

WIRELESS INSTALLATION

7

Open the battery compartment by removing the stainless steel screws in the cover. Insert the two 1000 Milliamp **Ni-Cad** batteries that have been fully charged per the charger instructions. The test light in the wireless transmitter will blink once to indicate that the batteries have been installed properly.

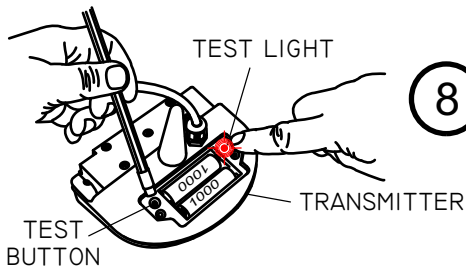
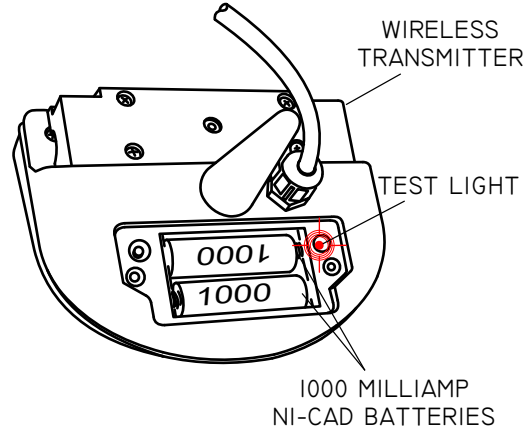

8

Plug in the 12 volt power supply that is connected to the instrument and the receiver. Test the transmitter by depressing the test button. After a few seconds the test light should blink every two seconds. This indicates that the transmitter is in test mode, which lasts for 15 minutes. At the end of 15 minutes the transmitter will return to normal operating mode. After initial power up, the indicator light on the receiver should blink red every two seconds. This indicates proper communication between the receiver and the wind transmitter. (NOTE: If more than 15 minutes has passed since the button on the wind transmitter was pushed it will need to be pushed again.) The light on the receiver will blink other colors when different sensors are installed.

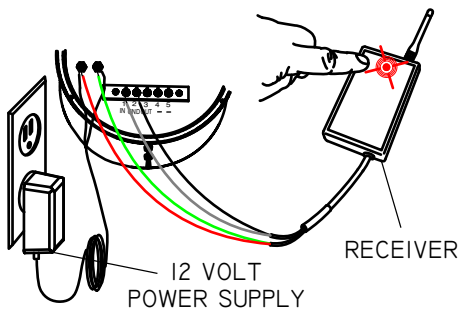

RECEIVER INDICATOR	TRANSMITTER
RED.....	WIND
GREEN.....	TEMPERATURE
ORANGE.....	RAIN

MAXIMUM INC.

30 Barnet Boulevard
New Bedford, MA 02745
(508) 995-2200
Page 3

MAESTRO

WIRELESS INSTALLATION

9

Perform a test of your wireless MAESTRO. Spin the cups on the wind sensor and a speed should be indicated on the dial (there will be a brief delay). Slowly rotate the vane on the wind direction sensor and the lights indicating wind direction should change (again, there will be a brief delay).

If the above tests do not produce the results described, refer to the trouble-shooting section at the back of this manual for assistance.

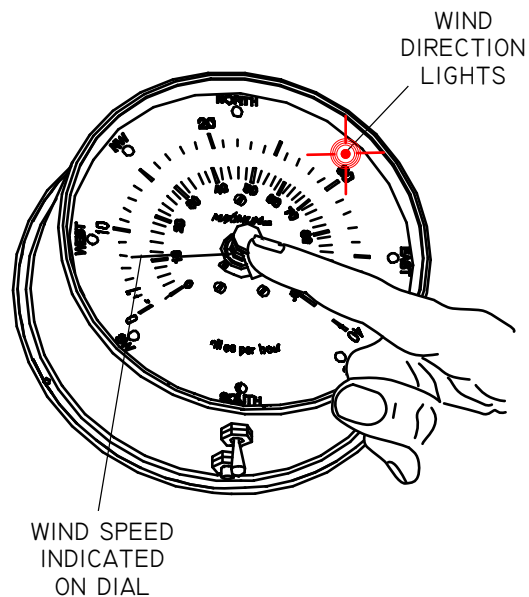

10

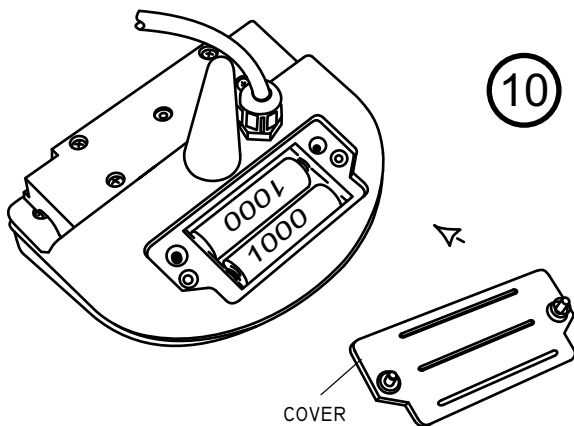

Replace the plastic battery cover. Make sure to seat the cover properly over the glued in gasket.

11

Mount the Wireless Wind Transmitter to the "Z" shaped arm. Remove the four stainless steel screws holding the locking bracket. Place the transmitter over the arm as shown. Insert one stainless steel screw through the center of the locking bracket and into the alignment hole in the z-shaped arm. Re-attach the locking bracket with the four remaining stainless steel screws.

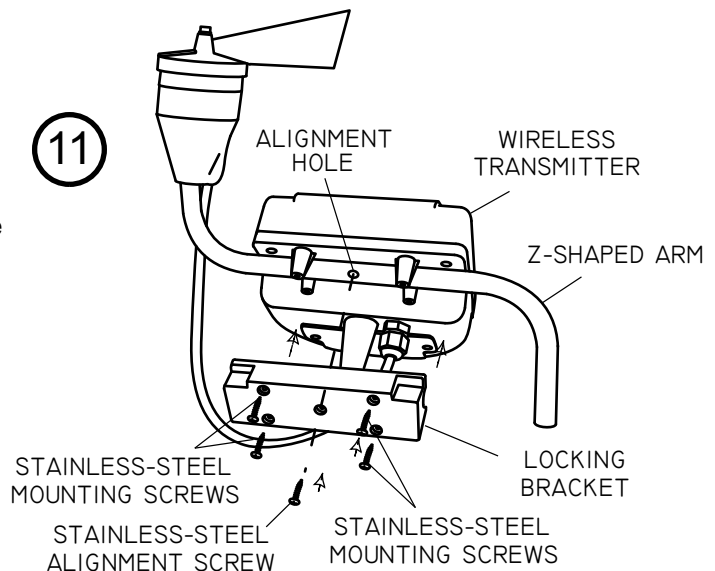

MAXIMUM INC.

30 Barnet Boulevard
New Bedford, MA 02745
(508) 995-2200

MAESTRO

WIRELESS INSTALLATION

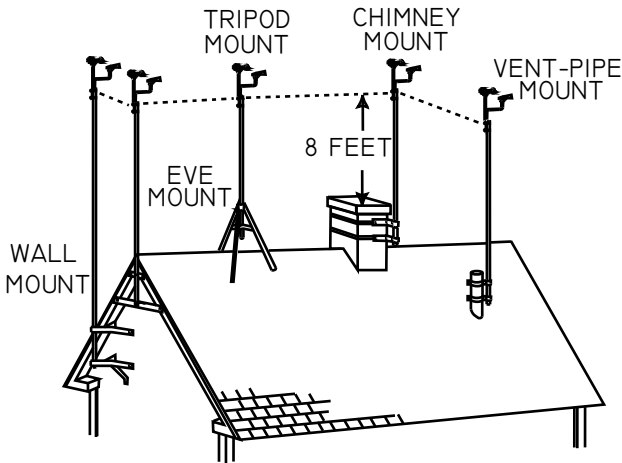

12

A mounting mast and bracket for your particular situation will need to be purchased. Radio Shack and home supply stores often have a selection of masts and mounting brackets. The ideal mounting mast and bracket should provide approximately eight feet of vertical clearance above nearby obstacles. Do not use a mounting mast made of fiberglass or PVC plastic because of electrical grounding considerations. Check with local building/electrical code enforcement officer about mounting mast grounding requirements.

13

Secure the sensors and stub masts to the mounting mast with the two hose clamps provided (see illustration). Move the completed mast assembly as close as possible to your preferred final mounting location. Also move the instrument meter and receiver combination as close as possible to their final mounting location. Check to make sure that proper communication between the receiver and transmitter still exists by verifying that the light on the receiver is still flashing red every two seconds. NOTE: If more than 15 minutes has passed since the button on the wind transmitter was pushed, it will need to be pushed again (see step 8). If the signal has been lost, move to an alternate installation location for a better signal with the receiver flashing every two seconds.

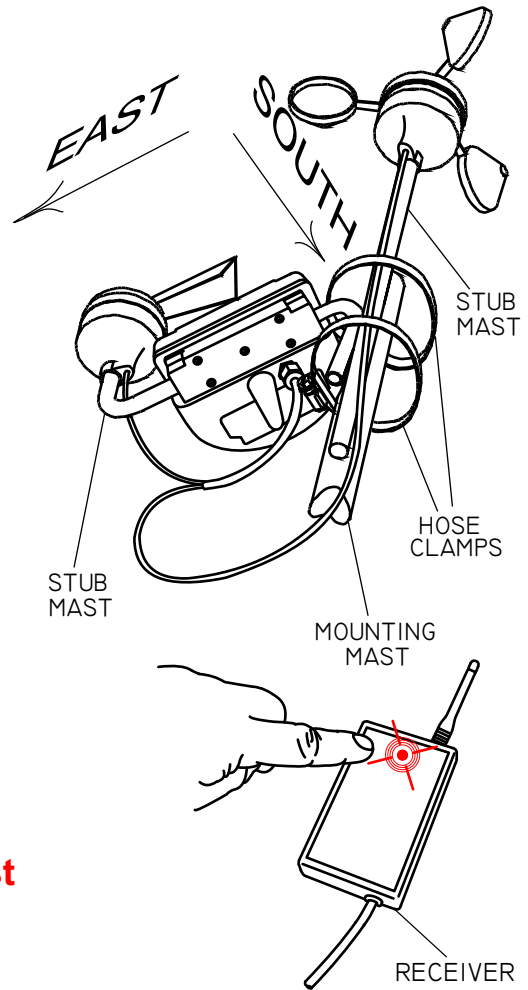

14

Permanently install the mounting mast and brackets following the manufacturer's instructions (See illustration, step 13).

Make sure that the "z" shaped arm is facing east and the solar panel is facing south

MAXIMUM INC.

30 Barnet Boulevard
New Bedford, MA 02745
(508) 995-2200
Page 5

MAESTRO

WIRELESS
INSTALLATION

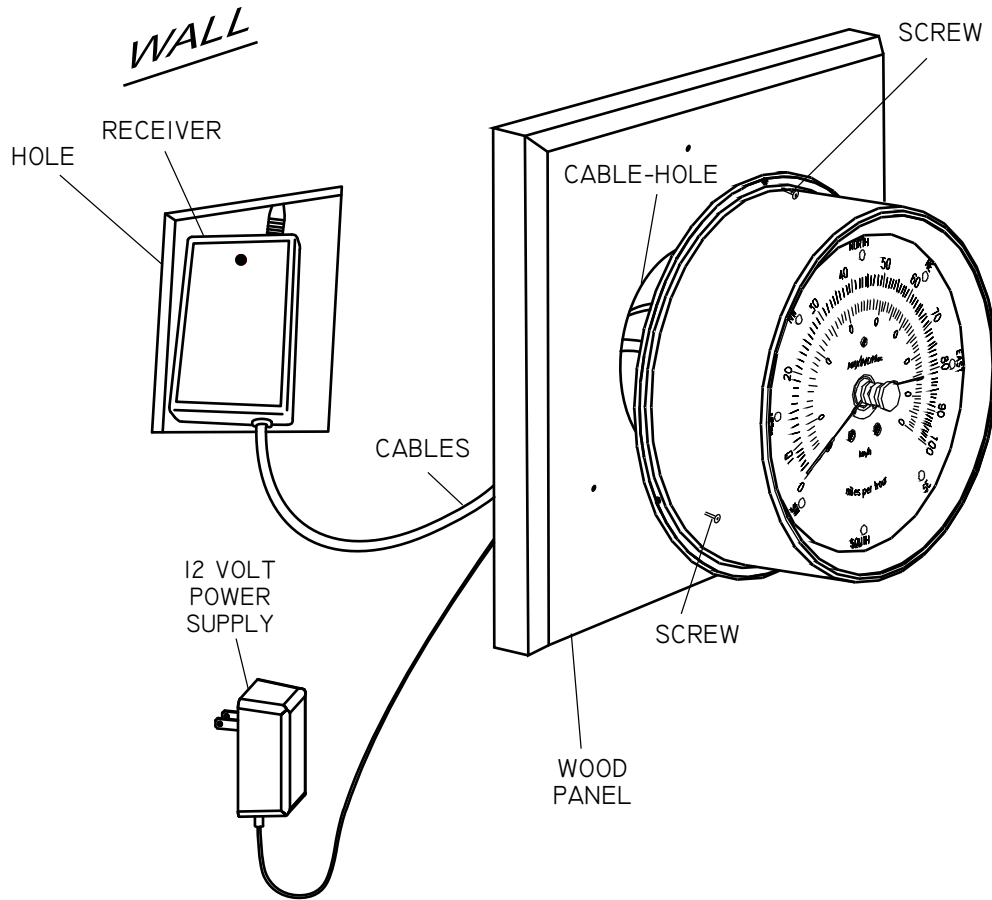

15

Mount the brass instrument meter directly over the cable hole that is also used to route power to the instrument. For the cleanest installation, we recommend making a hole in the wall large enough to insert the wireless receiver. We also recommend mounting the brass meter to one of our pre-drilled mounting panels.

MAXIMUM INC.

30 Barnet Boulevard
New Bedford, MA 02745
(508) 995-2200

Page 6

MAESTRO

WIRELESS

OPTIONAL INSTALLATION

MAESTRO WITH MINI-MAX

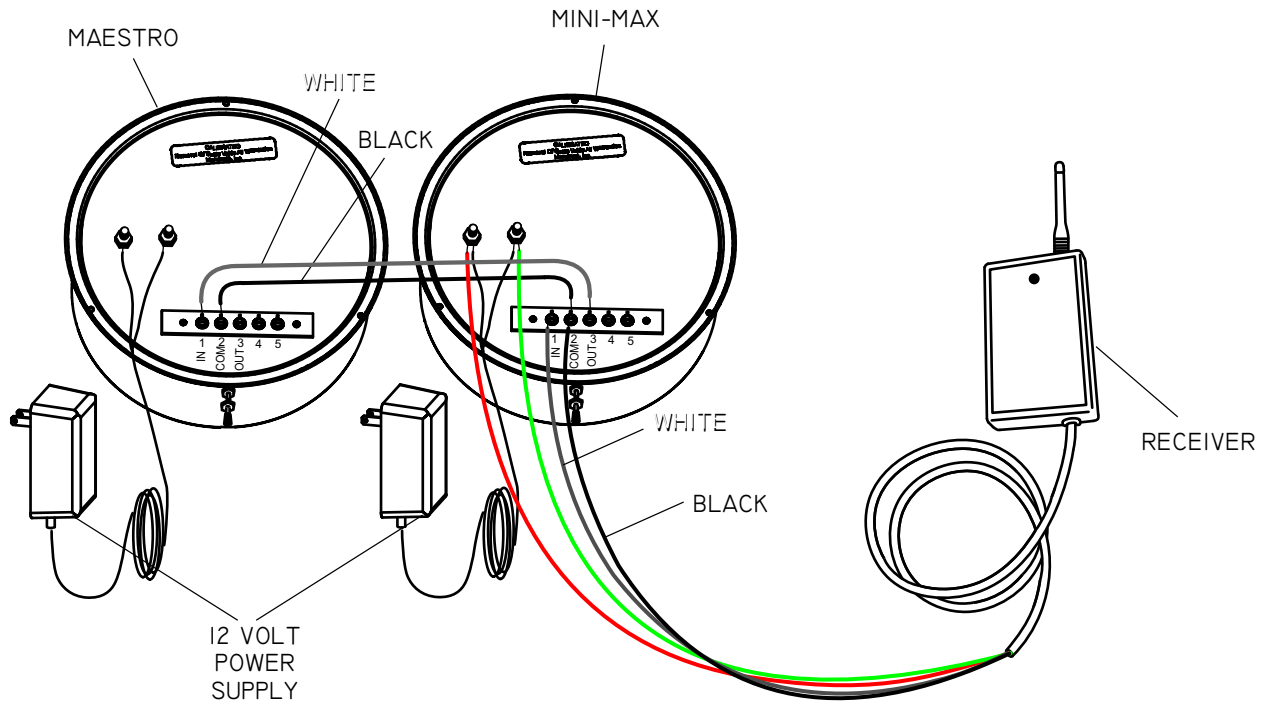

MAESTRO AND MINI-MAX CONNECTIONS

- ① Connect the **RED** and **GREEN** wires from the RECEIVER to the power terminals on the back of the MINI-MAX (no polarity).
Connect the wires from the 12 VOLT POWER SUPPLY to the same MINI-MAX power terminals (no polarity).
- ② On the MINI-MAX, connect the **WHITE** wire from the RECEIVER to TERMINAL #1 (IN) and the **BLACK** wire from the RECEIVER to TERMINAL #2 (COM).
- ③ Connect the two instruments using the supplied grey sheathed **BLACK** and **WHITE** wires as follows:
 - A. Connect the **WHITE** wire from MAESTRO TERMINAL #1 (IN) to MINI-MAX TERMINAL #3 (OUT)
 - B. Connect the **BLACK** wire from MAESTRO TERMINAL #2 (COM) to MINI-MAX TERMINAL #2 (COM)
- ④ Connect the wires from the 12 VOLT POWER SUPPLY to the MAESTRO power terminals (no polarity).

MAXIMUM INC.

30 Barnet Boulevard
 New Bedford, MA 02745
 (508) 995-2200
 Page 7

RAINWATCH

WIRELESS

OPTIONAL INSTALLATION

MAESTRO WITH MINI-MAX AND RAINWATCH

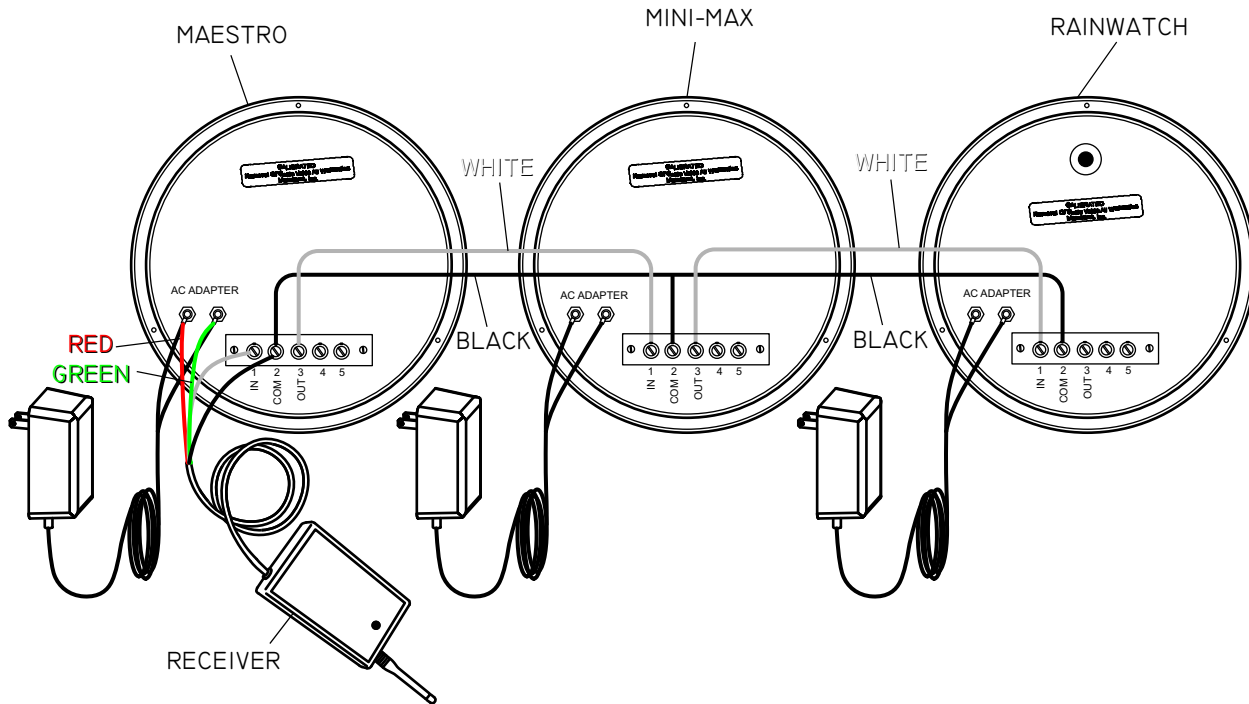

RAINWATCH WITH MINI-MAX AND MAESTRO CONNECTIONS

- 1 Connect the **RED** and **GREEN** wires from the RECEIVER to the power terminals on the back of the MAESTRO (no polarity).
Connect the wires from the 12 VOLT POWER SUPPLY to the same MAESTRO power terminals (no polarity).
- 2 On the MAESTRO, connect the **WHITE** wire from the RECEIVER to TERMINAL #1 (IN) and the **BLACK** wire from the RECEIVER to TERMINAL #2 (COM).
- 3 Connect the MAESTRO and MINI-MAX instruments using the supplied grey sheathed **BLACK** and **WHITE** wires as follows:
 - A. Connect the **WHITE** wire from MINI-MAX TERMINAL #1 (IN) to MAESTRO TERMINAL #3 (OUT).
 - B. Connect the **BLACK** wire from MINI-MAX TERMINAL #2 (COM) to MAESTRO TERMINAL #2 (COM).
- 4 Connect the MINI-MAX and RAINWATCH instruments using the supplied grey sheathed **BLACK** and **WHITE** wires as follows:
 - A. Connect the **WHITE** wire from RAINWATCH TERMINAL #1(IN) to MINI-MAX TERMINAL #3 (OUT)
 - B. Connect the **BLACK** wire from RAINWATCH TERMINAL #2(COM) to MINI-MAX TERMINAL #2(COM).

MAXIMUM INC.

30 Barnet Boulevard
New Bedford, MA 02745
(508) 995-2200

MAESTRO

WIRELESS OPERATION

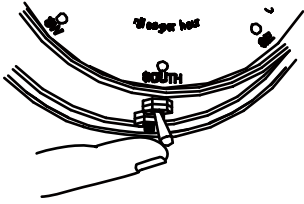

HIGHEST GUST

Holding the toggle switch to the right will display the speed and direction of the highest gust since the instrument was last reset.

AVERAGE WIND SPEED & DIRECTION

Lightly holding the toggle switch to the left will display the two minute average wind speed and prevailing direction.

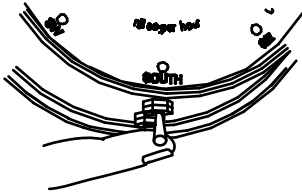
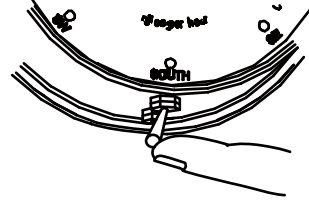

RESETTING MEMORY

To reset the gust register, average wind speed and direction recording, fully depress the small push button for five seconds. The MAESTRO will again begin storing new data.

TREND REGISTER POINTER

You can reset the Trend Register Pointer by turning the knob located in the center of the dial face.

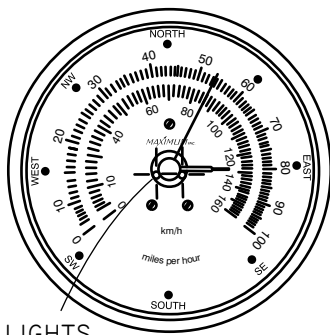
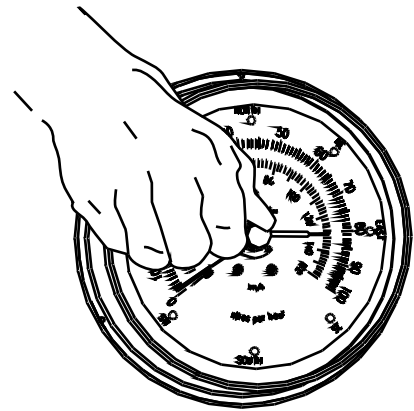

LIGHTS

EXTREMELY HIGH WIND SPEEDS

If the winds exceed 100mph, the instrument will automatically switch into double mode. Two lights in the center meter opening in the dial will flash simultaneously and the meter reading will indicate half the wind speed (75mph = 75 X 2 = 150mph). If the winds exceed 200mph, the instrument will automatically switch into triple mode. The two lights in the dial will light continuously and the reading will be one third the actual wind speed (75mph = 75 X 3 = 225mph). The MAESTRO will stay in triple mode until the wind drops below 150mph.

MAXIMUM INC.

30 Barnet Boulevard
New Bedford, MA 02745
(508) 995-2200

WIRELESS

TROUBLE-SHOOTING

THE FOLLOWING ILLUSTRATIONS SHOW HOW THE INSTRUMENT DIAL WILL INDICATE IMPROPER OPERATION.

NO SERIAL DATA

(Instrument has never recognized a receiver)

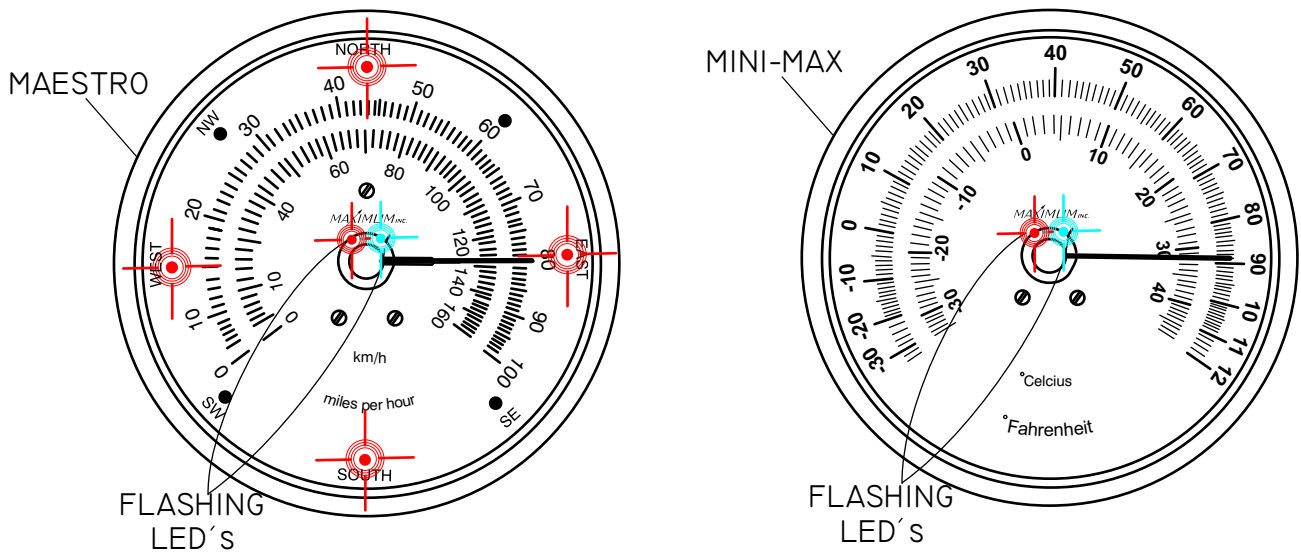

SYMPTOM:

- The pointer is in the 3 o'clock position
- The central LED's are flashing
- The (Maestro) primary direction LED's are illuminated

REMEDY:

- Check all wire connections (Refer to installation diagrams)
- Re-boot the system by unplugging the power supply, wait 30 seconds, plug it back in.
- The light on the receiver will flash **RED** and then **GREEN** five times, indicating that the receiver is now powered-up.
- If the instrument continues to display the error code, call Maximum for further assistance.

Note: Depending on the origin of the problem, error codes may not display on all instruments.

MAXIMUM INC.

30 Barnet Boulevard
New Bedford, MA 02745

(508) 995-2200

Page 10

WIRELESS

TROUBLE-SHOOTING

NO SIGNAL FROM ANY TRANSMITTER

(Instrument recognizes the receiver, but the receiver does not recognize the sensor(s).)

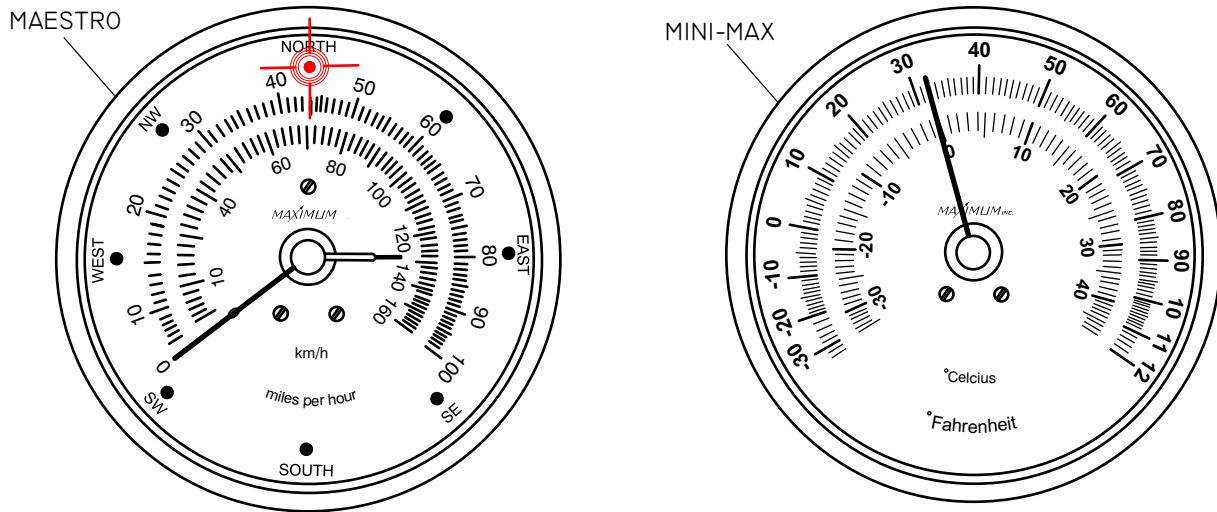

SYMPTOM:

- Maestro needle points to 0 MPH
- Mini-Max needle points to 32°F (or 0°C)

REMEDY:

- Test the batteries in each external SENSOR/TRANSMITTER and replace if necessary.
- Put the TRANSMITTER(S) into TEST MODE by pressing TEST BUTTON in the battery compartment of TRANSMITTER.
- Remove the RECEIVER from the wall and confirm receipt of TRANSMISSION(S) based on the color of the flashing light.

RECEIVER INDICATOR	TRANSMITTER
RED	WIND
GREEN	TEMPERATURE
ORANGE	RAIN

-If the instrument continues to display the error code, call Maximum for further assistance.

Note: Depending on the origin of the problem, error codes may not display on all instruments.

MAXIMUM INC.

30 Barnet Boulevard
New Bedford, MA 02745
(508) 995-2200

WIRELESS

TROUBLE-SHOOTING

NO SIGNAL FROM WIND TRANSMITTER (Instrument has received, then lost sensor(s) signal)

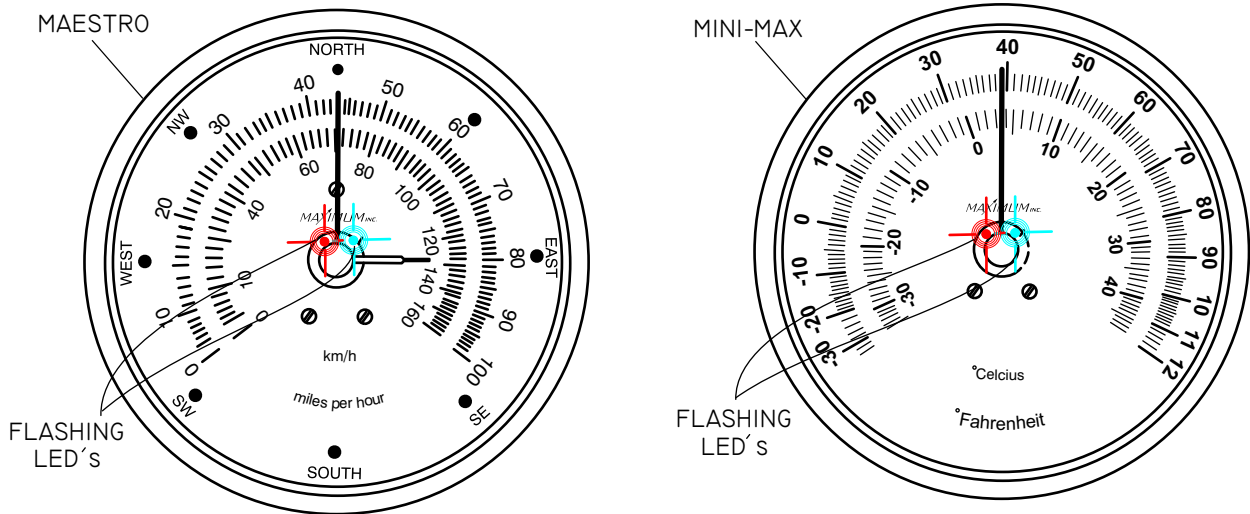

SYMPTOM:

- The pointer is in the 12 o'clock position.
- Central LED's flashing.

REMEDY:

- Re-charge and/or replace the **AA NiCad** batteries in the WIND TRANSMITTER.
- Put TRANSMITTER(S) into TEST MODE by pressing the TEST BUTTON in the battery compartment of TRANSMITTER. This should cause the LED on the receiver to flash **RED** every 2 seconds.
- If the instrument continues to display the error code, call Maximum for further assistance.

MAXIMUM INC.

30 Barnet Boulevard
New Bedford, MA 02745
(508) 995-2200
Page 12

WIRELESS

TROUBLE-SHOOTING

NO SIGNAL FROM TEMPERATURE TRANSMITTER (Instrument has received, then lost sensor(s) signal)

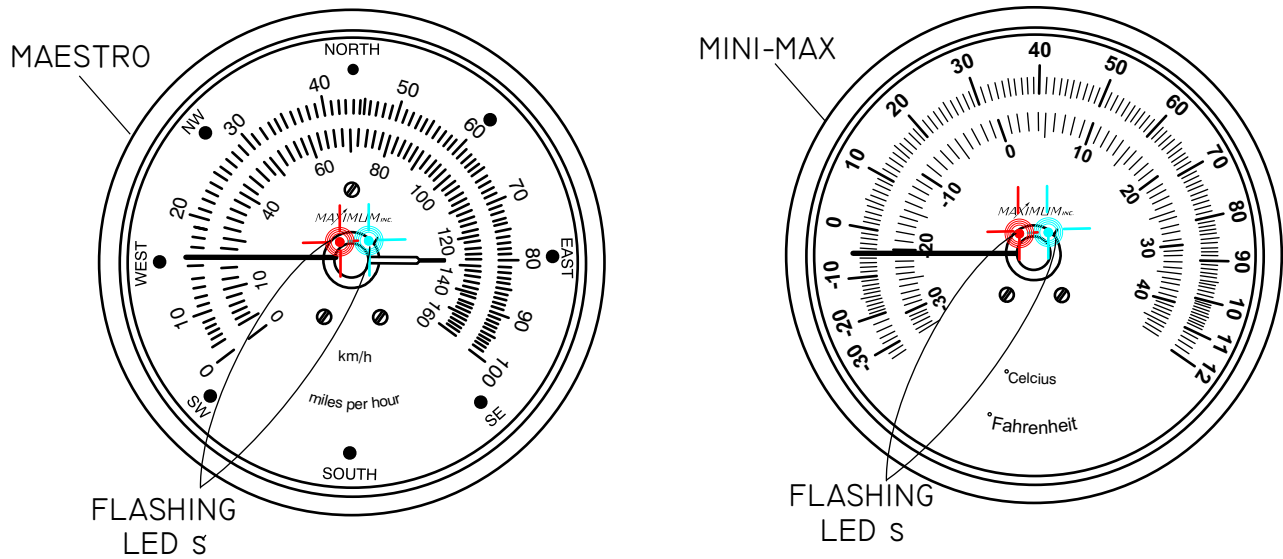

SYMPTOM:

- The pointer is in the 9 o'clock position.
- Central LED's flashing.

REMEDY:

- Check and replace (if necessary) the AA Alkaline batteries in the TEMPERATURE TRANSMITTER.
- Put TRANSMITTER(S) into TEST MODE by pressing the TEST BUTTON in the battery compartment of the TRANSMITTER. This should cause the LED on the receiver to flash **GREEN** every 4 seconds.
- If the instrument continues to display the error code, call Maximum for further assistance.

MAXIMUM INC.

30 Barnet Boulevard
New Bedford, MA 02745
(508) 995-2200

WIRELESS TROUBLE-SHOOTING

NO SIGNAL FROM RAIN TRANSMITTER (Instrument has received, then lost sensor(s) signal)

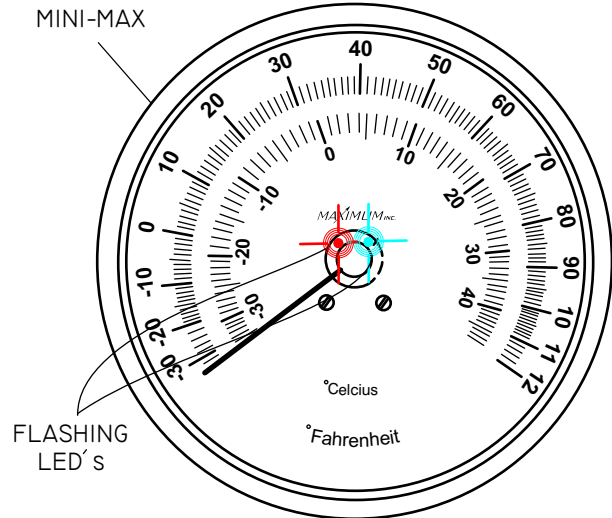
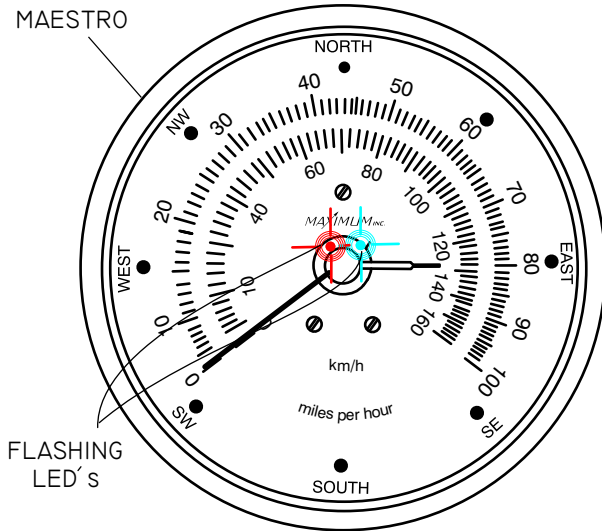

SYMPTOM:

- Maestro needle points to 0 MPH.
- Mini-Max needle points to -35°.
- Central LED's flashing.

REMEDY:

- Remove and test the AA Alkaline batteries in the RAIN TRANSMITTER. If dead, replace batteries and check operation. If good, continue to next step.
- Put the RAIN TRANSMITTER into TEST MODE by removing the batteries, then moving the jumper on the RAIN TRANSMITTER circuit board to cover both pins of the 2-pin terminal.

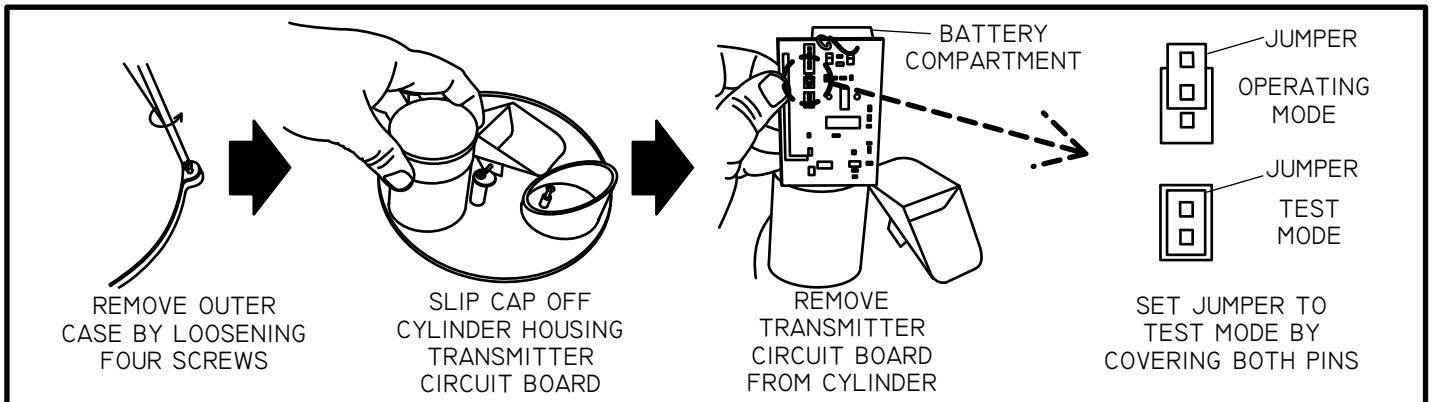

- Re-install the AA Alkaline batteries in the RAIN TRANSMITTER once the jumper has been moved.
- Check LED on receiver to make sure it is blinking **ORANGE** every 4 seconds.
- Check the instruments to see if the error has been corrected.
- Unlike the WIND and TEMPERATURE TRANSMITTERS, the RAIN TRANSMITTER will not automatically exit test MODE after 15 minutes. Therefore, you must take the rain transmitter out of test mode manually. To do so: remove the batteries, then move the jumper on the RAIN TRANSMITTER circuit board back to covering only one pin of the 2-pin terminal (it does not matter which pin is covered). Re-install the batteries and cover.
- If the instrument continues to display the error code, call Maximum for further assistance.

MAXIMUM INC.

30 Barnet Boulevard
New Bedford, MA 02745
(508) 995-2200



Electrical Damage - Common Causes & Recommended Prevention

Electrical damage can be caused by many different factors. Below are some of the more common causes and some suggested methods of minimizing potential problems.

Common Causes:

Storm Activity - lightning in your area can do damage to your instruments in different ways. The obvious way is due to a direct or nearby strike. In addition, lightning storms, dust storms, dry snowstorms and strong dry winds can all cause static electricity to build up on and around your external sensors. Regardless of the cause, this built up electricity itself through the cable connecting the external sensors to the instrument.

Power Surges - A surge may come from the electric company's switching generators or power grids, from local industries or after power interruption when accumulated power suddenly surges back through AC lines. Even the on-and-off switching of large electrical appliances, such as refrigerators or clothes dryers can create damaging fluctuations. This is especially true with sensitive weather recording devices.

Yourself - Are you constantly giving and/or receiving a shock every time you touch a doorknob or other person? If so, you have a great deal of static electricity in your environment. In either case, it is possible for a person to carry enough of a charge to damage an instrument.

Recommended Prevention:

Ground Your Mounting Mast – IMPORTANT: PVC and fiberglass are not recommended mast materials as they can store high amounts of static electricity within themselves. It is recommended that you follow the grounding instructions that came with your mounting mast, while also maintaining accordance to your local Electric Code. In the absence of instructions for your mast system, the following generic guidelines from the National Electric Code may be helpful.

- 1) The NEC requires that the antenna mast and mount be grounded directly. No splices or connections are allowed in the ground wire between the mast and the ground rod.
- 2) Attach one end of a No. 8 (or thicker) copper or aluminum ground wire to the antenna mast. Note: As static electricity issues are more common for weather sensors than direct lightning strikes, consider installing the ground wire as physically close to the wind sensors as possible to best combat static electricity issues. For multi-piece (or telescoping) masts, consider connecting the ground to each separate section of the mast.
- 3) For painted or coated masts, scrape off the coating around the area where the contact will be made. This will ensure a good, solid connection. (Once the ground is attached to the mast, any scraped off portion that is exposed should be recoated with paint or other sealant.)
- 4) Next, run the ground wire to ground as directly as possible. Standard wire staples can be used to secure the ground wire against the side of the house. Avoid making 90° or sharper turns with the ground wire. A lightning charge has difficulty making such a turn and therefore may discharge into the house. Make ground wire bends as smooth and as gradual as possible.
- 5) The ground wire must be connected to a ground rod. Water pipes or plumbing fixtures are not acceptable. A good copper-coated steel ground rod driven at least 3 feet into the ground is required. Special clamps that provide a solid connection between the ground wire and ground rod should be used

Use Surge Protectors - for the AC adapter, a UL 1449 rated surge protector with EMI/RFI filtering is recommended. This rating will be clearly listed on the packaging of all good quality surge protector.

Discharge Yourself - If the instruments are located in an environment where static electricity is a problem, make sure that you discharge yourself before touching the instrument(s). The shock that you get from touching a doorknob or another person can often be sufficient to damage an instrument.

**30 SAMUEL BARNET BOULEVARD ✦ NEW BEDFORD, MASSACHUSETTS 02745 U.S.A.
TEL. 508.995.2200 ✦ WWW.MAXIMUM-INC.COM ✦ FAX 800.989.2580**